

RCS Rail Climbing System

The universal climbing construction kit for safe working at great heights

Product Brochure

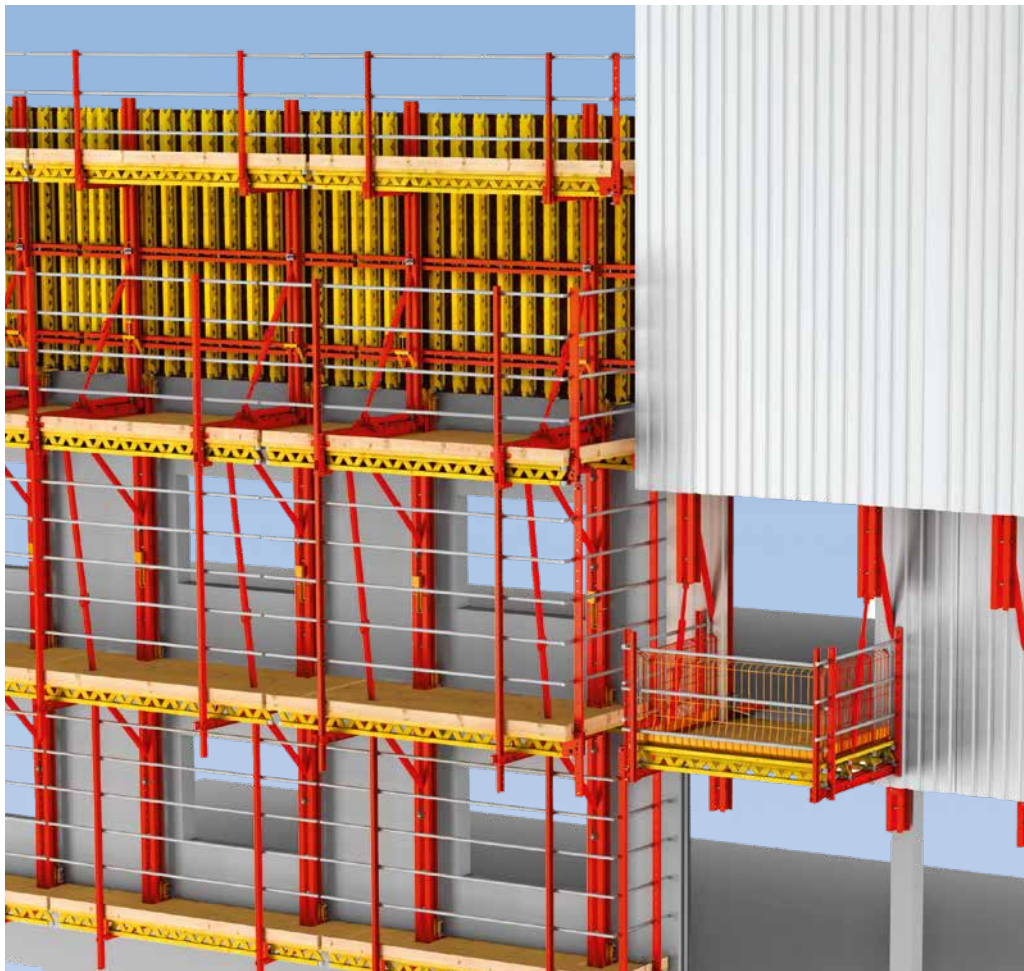

Edition 04 | 2016

PERI AG
Formwork Scaffolding Engineering

Rudolf-Diesel-Strasse 19
89264 Weissenhorn
Germany
Tel. +49 (0) 7309.950-0
Fax +49 (0) 7309.951-0
info@peri.com
www.peri.com

Important notes

All current safety regulations and guidelines must be observed in those countries where our products are used.

The images shown in this brochure feature construction sites in progress. For this reason, safety and anchor details in particular cannot always be considered as conclusive or final. These are subject to the risk assessment carried out by the contractor.

In addition, computer graphics are used which are to be understood as system representations. For ensuring a better understanding, these and the detailed illustrations shown have been partially reduced to certain aspects. The safety installations which have possibly not been shown in these detailed descriptions must nevertheless be available.

The systems or items shown might not be available in every country.

Safety instructions and load specifications are to be strictly observed at all times. Separate structural calculations are required for any deviations from the standard design data.

The information contained herein is subject to technical changes in the interests of progress. Errors and typographical mistakes reserved.

Content

RCS Rail Climbing System

- 2 The universal climbing construction kit for safe working at great heights

Climbing formwork solutions for your projects

- 4 Detailed planning and competent support throughout the entire project

RCS Climbing Formwork

- 8 RCS C with Carriage for standard applications
- 10 The lightweight RCS CL Self-Climbing Formwork
- 12 The non-guided, crane-climbed RCS CB version
- 14 Reference projects

RCS P Climbing Protection Panel

- 16 Fall protection, weather protection and advertising space all at the same time
- 18 Enclosure variants for all requirements
- 20 Reference projects

RCS MP Landing Platform and RCS ML Material Lifter

- 22 Flexible solutions for moving loads with and without a crane

Special solutions with the RCS Rail Climbing System

- 26 Wide range of possibilities thanks to the construction kit logic

RCS Anchoring

- 28 Flexible mounting solutions for the RCS Rail Climbing System

RCS Self-Climbing Hydraulics

- 30 Cost-effective climbing without use of a crane with mobile RCS Climbing Devices

RCS Rail Climbing System

The universal climbing construction kit for safe working at great heights

PERI RCS (Rail Climbing System) combines the advantages of different climbing systems to create one single construction kit. The rail climbing system can be used as climbing formwork as well as a climbing protection panel and can easily be adapted to meet specific site requirements.

As climbing formwork as well as climbing protection panel, RCS is the most cost-effective solution for a wide range of projects. Through the rail guidance, the climbing procedure is fast and safe, even in windy conditions. The climbing units are moved with the crane or optionally using mobile climbing

hydraulics. In addition, the RCS components can be used for countless, site-specific solutions. In combination with components of the VARIOKIT Engineering Construction Kit, this results in e.g. landing platforms for transporting materials or optimized project-specific truss constructions.

■ Safe rail-guided procedure

The moving unit is connected to the building at all times by means of climbing shoes

■ Flexible mounting

The climbing shoe can be attached to walls as well as slab edges

■ Variable assembly

Due to the 125 mm hole arrangement of the climbing rails, the platforms can be optimally adapted to suit the respective storey heights

RCS C Climbing Formwork and
RCS P Climbing Protection Panel



RCS core components

RCS Climbing Rail

The universal steel profile for climbing applications and as a core component in the VARIOKIT Engineering Construction Kit available in lengths from 1.48 m to 9.98 m

RCS Climbing Shoe

Guidance and bearing support for RCS Climbing Rails with foldable guidance skids and self-acting bearing pawl

RCS 50 Climbing Device

For crane-independent climbing of RCS climbing units with 5 t lifting force



RCS as RCS C Climbing Formwork

Rail-guided and optional self-climbing platforms with retractable wall formwork

RCS as RCS P Climbing Protection Panel

Windshield, anti-fall protection and protection against falling objects

RCS for special applications

Here as self-climbing shaft platform with shaft internal formwork

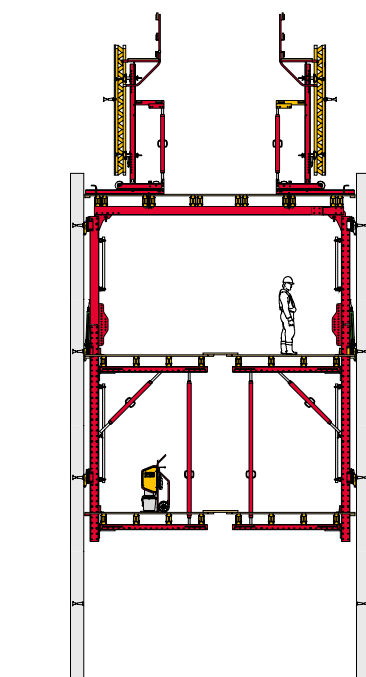
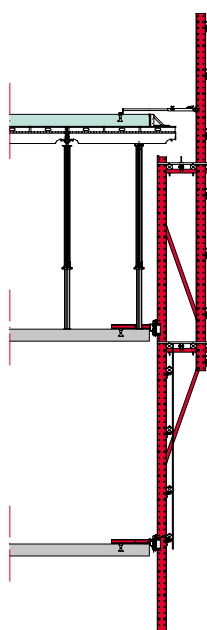
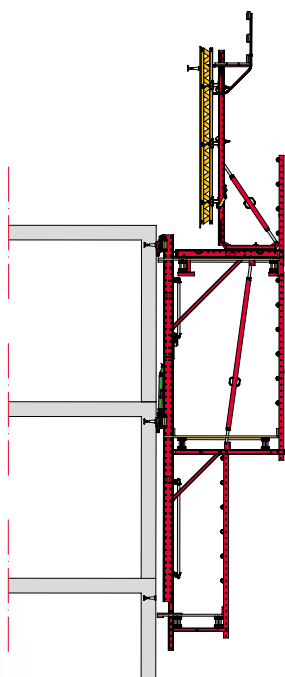

Climbing formwork solutions for your projects

Detailed planning and competent support throughout the entire project



PERI Engineering stands for project-specific complete solutions comprised of efficient formwork and scaffolding systems, optimized planning and continuous support for the execution.

Planning is teamwork: with their expert knowledge and experience from hundreds of projects, PERI engineers optimize the customized solutions for our customers.

In very close cooperation with our customers, PERI engineers plan technically and cost-effectively optimized climbing solutions. In the process, they use their extensive experience gained from a wide range of projects worldwide. The solution also includes extensive technical documentation – from detailed execution drawings through to verifiable static calculations. In addition, 3D animations can be used to simulate extremely clearly the workflows and safety concepts in advance and to ensure interference-free planning.

The 3D animation in comparison with the realized project. The clear presentation is particularly suitable for training purposes and helps with the optimization of the work processes.

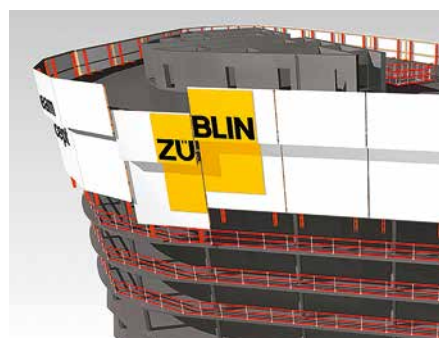
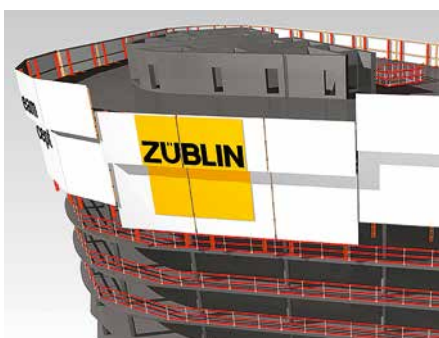

Protected by the RCS Climbing Protection Panel, the two twisted Absolute World Towers in Mississauga, Canada, were climbed upwards using regular weekly cycles – on the northern tower, even winding around the building like a spiral. Integrated landing platforms ensure simple and fast transport of materials.



Climbing formwork solutions for your projects

Detailed planning and competent support throughout the entire project

We also provide the best support for cost-effective implementation of the planning – continuously from material delivery, installation and execution through to final return deliveries.

Worldwide, over 110 logistics centres guarantee high material availability and fast delivery of materials. As the RCS system components are available in the rental park, they can be rented on a project-related basis according to specific needs. This makes RCS solutions extremely economical for our customers.

On request, our supervisors will provide the briefing regarding the operation and handling of the PERI system equipment on the construction site, for any necessary assembly work and during initial operations. As a result, use of the PERI formwork and scaffolding technology is safe and efficient right from the very beginning.



PERI Engineering means

Optimized solutions

Project-specific customized planning

A personal contact Partner

Continuous project support and technical advice from a PERI specialist – if required, also directly on the jobsite

Application safety and reliability

Through detailed drawings and, if required, auditable static calculations



PERI sales engineers and supervisors provide active on-site assistance in order to ensure the most efficient execution.

From the Instructions for Assembly and Use along with Instructions for Use through to auditable, static calculations – we provide the respective technical documentation required for every project.

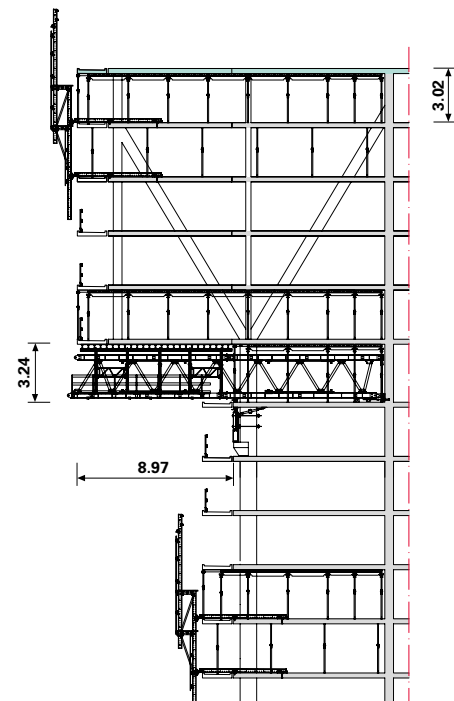

De Rotterdam, Rotterdam, Netherlands
 Complete enclosure with the RCS P Climbing Protection Panel provided maximum protection and facilitated a safe and fast working environment in the two topmost floors under construction. An important element of the PERI solution was the VARIOKIT truss construction for supporting the up to 9 m cantilevered floors at the halfway point of the building.

RCS Climbing Formwork

RCS C with Carriage for standard applications

The RCS C Rail Climbing Formwork is the system for standard applications with 2.70 m to 4.50 m high wall formwork.

The climbing procedure with RCS C is fast and safe at all times because the moving unit is always connected to the building by means of climbing rails. The 125 mm hole pattern of the climbing rails allows optimum adaptation of the platforms to suit the floor height. The climbing units can be quickly and safely moved with the crane through the continuous climbing rail.

As an option, the mobile self-climbing hydraulics provide crane-independent climbing to the next floor.

The formwork is securely installed on a smooth running, roller-mounted carriage which can be retracted by up to 90 cm.

The formwork

Both the VARIO GT 24 Girder Wall Formwork as well as panel formwork such as TRIO can be adjusted in all directions when mounted on the strongback.

The working platforms

The position of the working platforms is adjusted to suit the floor height. This results in safe and fast access possibilities to the platforms through openings in the building.

The guardrails

Handrail boards or scaffold tubes provide the required level of safety when working on the platforms. 2.00 m high guardrails on the main working platform guarantee an enhanced level of safety. Alternatively, a complete enclosure is possible.

RCS C with Carriage for rail-guided climbing of wall formwork – self-climbed is available as an option.

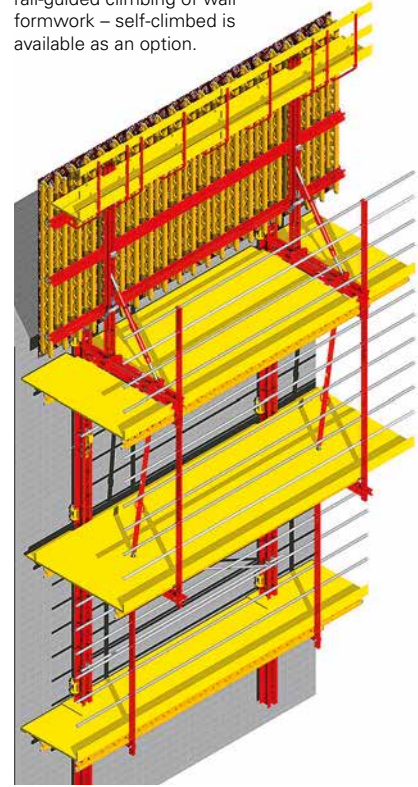

The climbing procedure

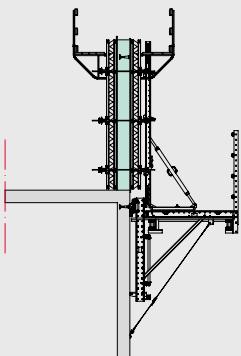

Use of climbing formwork on the first casting segment.

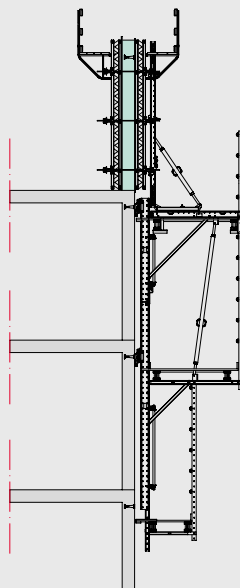

Concreting of the standard cycle with the complete system.

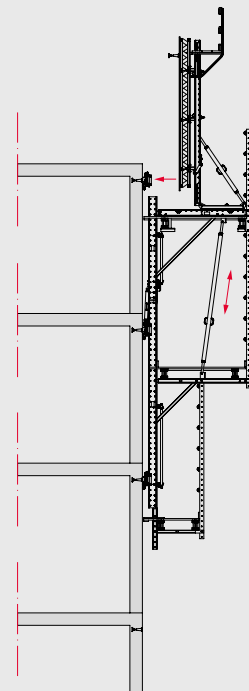

Rail-guided climbing with the crane or mobile climbing hydraulics.

The structural system

The RCS structural system consists of two bracket units arranged on top of each other which are connected with each other by a hinge in the climbing rail and a spindle. When extending the spindles, the movable construction tilts inwards thus allowing wall recesses to be climbed over.

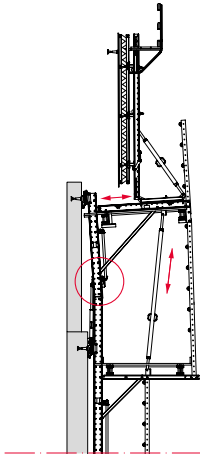

The RCS Carriage

The formwork is connected to the carriage by means of SRU Strongbacks and SLS Spindles. Due to the front roller bearings, it can be easily and smoothly retracted up to 90 cm. The self-locking capability of the gear safely fixes the carriage in every position without requiring any additional tools. The SLS Spindle is used for adjusting the formwork inclination whereby the height is adjusted using the height adjustment unit.



The anchoring

Standard anchoring of the RCS Climbing Scaffold is carried out with the Wall Shoe and RCS Climbing Shoe. The components are very light and can be quickly mounted. PERI Climbing Anchors have a building authority approval, so the high load-bearing capacity and quality are certified.

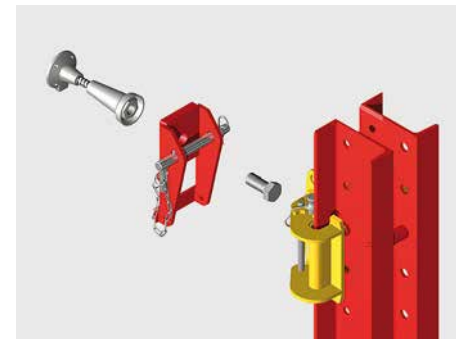

The RCS Climbing Formwork with continuous high side protection provides safe working areas at great heights.

RCS Climbing Formwork

The lightweight RCS CL Self-Climbing Formwork for medium-height buildings with limited crane availability

The lightweight RCS CL Self-Climbing Formwork is ideally suited for external facades as well as cores of medium-height structures formed in advance. Also on construction sites with limited crane availability, this variant of crane-free climbing provides enormous advantages.

The RCS CL differs in that only one finishing platform is used. For this variant, climbing rail extensions and intermediate climbing shoes are utilized.

The Climbing Rail Extension

After installation of the Climbing Rail Extension, the mobile climbing device is mounted from a position on the main platform. This allows the system to climb without a crane from the first section onwards.

The Intermediate Climbing Shoe

The additional shoes, positioned at the halfway point of the section height, allow rail-guided climbing even with shorter climbing rails. Dismantling of the Intermediate Climbing Shoe is carried out from the finishing platform. Therefore the climbing procedure is briefly interrupted.

The variant with only one finishing platform saves assembly time and space requirements down below.



The climbing procedure

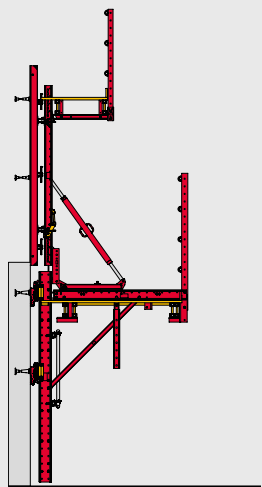

Use of the RCS CL on the first casting segment.

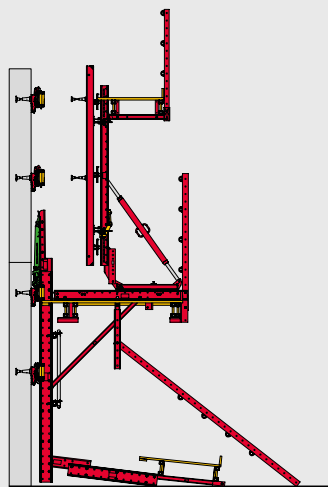

Mounting of the finishing platform and installation of the self-climbing hydraulics.

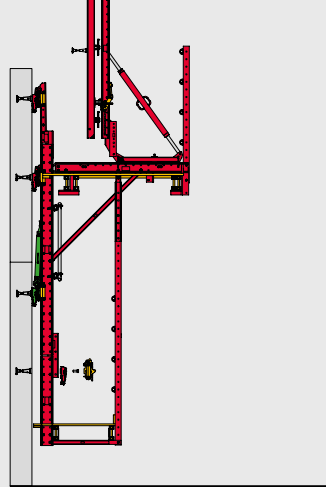

Dismantling the Intermediate Climbing Shoe from the finishing platform.

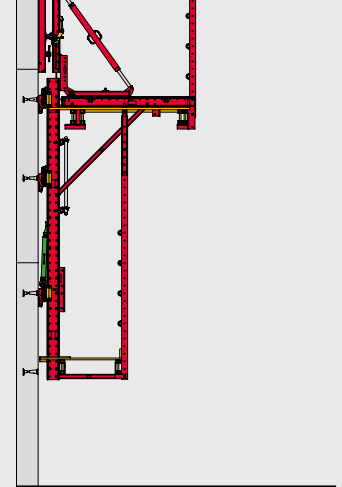

Concreting of the standard cycle with the RCS CL Self-Climbing Formwork.

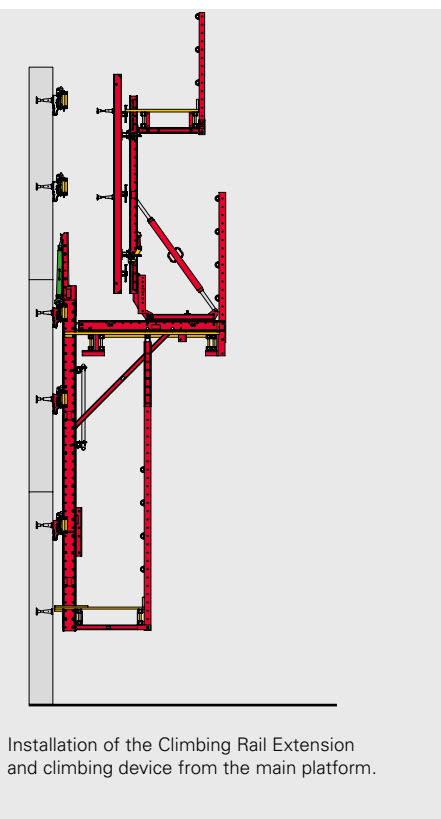

Installation of the Climbing Rail Extension and climbing device from the main platform.



The use of the lightweight rail-guided climbing formwork for a circular structure with the VARIO GT 24 Girder Wall Formwork.

The RCS CL climbs steadily upwards on these building cores without a crane – in part even without finishing platform. Dismantling of the Intermediate Climbing Shoes is carried out from a safe position on the following slab.

RCS Climbing Formwork

The non-guided, crane-climbed RCS CB version

Especially for construction sites with sufficient crane capacity or if rail-guided climbing is not feasible, the non-guided, crane-climbed RCS CB version is a useful solution.

Areas of application for the RCS CB are medium-height buildings with a limited number of storeys. An advantage of the non-guided version is that laterally off-set climbing is likewise possible as in those situations when climbing over obstacles.

If required, the traditional climbing procedure can be converted into self-climbing, rail-guided climbing units using the same components. This saves costs regarding material requirements and transport, and leads to greater efficiency through mixed application.

Platform and formwork are moved together as one unit. The formwork is connected to the smooth-running carriage – complete with roller bearings – by means of SRU Strongbacks and SLS Spindles.

Bridging larger openings

The pressure point of the bracket is adjustable in 125 mm increments, and can also bridge large openings in the structure thanks to the RCS Climbing Rail. The Tension Belt 25 kN serves as wind bracing.



The RCS Lifting Beam

The Lifting Beam 10 t is a lifting accessory for moving heavy RCS Climbing Units with the crane. The length of the Lifting Beam can be adjusted to suit the respective bracket spacing in 125 mm increments. A compression brace between the strongbacks is therefore not required as no diagonal pull occurs.

For symmetrical loads, the maximum load-bearing capacity is 10 t. With asymmetrical units, each lifting chain carries a maximum of 5 t. In this case, the one-sided chain shortener is to be used in order to position the crane hook above the centre of gravity. In this way, the load is horizontally aligned.

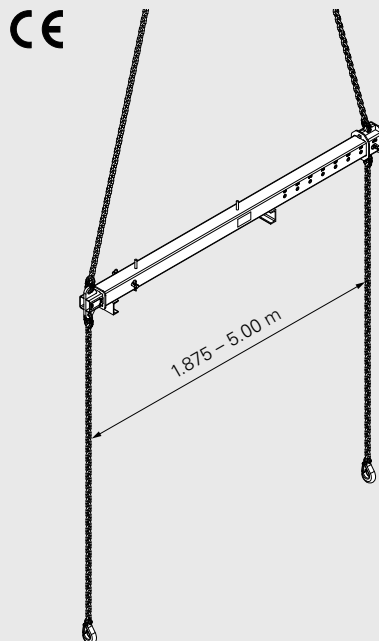

The suspension

The Mounting Ring Adapter M30 with safety pins provides the connection to the climbing anchor with the scaffold mounting ring. This simple suspension allows very large units due to the high load-bearing capacity.

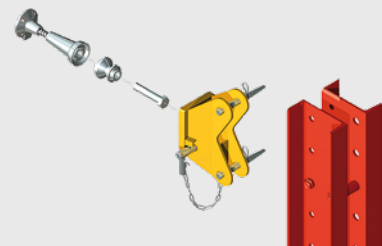



Avala TV Tower, Belgrade, Serbia

A gigantic tripod forms the base of the 200-metre high TV tower. The base supports with changing cross-sections were formed using VARIO GT 24, raised formwork units comprised of VARIOKIT elements supported the forward and reversed-inclined formwork panels. Diagonally arranged climbing RCS CB Climbing Formwork could subsequently be converted to RCS C Self-Climbing Units for the vertical upper part of the tower.

RCS Climbing Formwork

Reference projects



RCS provides safe working areas at the highest level – here completely enclosed.



As an alternative to complete enclosure, scaffold tubes or handrail boards also provide safe lateral protection.



This column formwork in the facade area climbs crane-independently upwards with the RCS Self-Climbing Technology. At the same time, the enclosure provides protection against wind and weather.



With the RCS Rail Climbing System, different wall formwork systems are used as well as the proven TRIO panel formwork.



Safe working conditions with continuous lateral and rear protection on and under the RCS C Climbing Formwork.



Complicated layouts can also be cost-effectively climbed with the RCS C formwork scaffold thanks to the flexibility – rail-guided and crane-independently.



Another typical area of application for the RCS Rail Climbing System is bridge piers.



The RCS Rail Climbing System used as formwork scaffold for the building core and as a climbing protection panel on the facade.

RCS P Climbing Protection Panel

Fall protection, weather protection and advertising space all at the same time

The RCS Climbing Protection Panel completely encloses the top floors of the building shell which are under construction. The enclosure protects site personnel against falling and strong winds at great heights. A positive side effect is that the protection panel can be used as highly visible advertising billboards.

Anchoring to the building is carried out by means of Slab Shoes or Slab Stopend Shoes with Climbing Shoes which guide the climbing rails and panel up the building during the climbing procedure. This ensures a fast and safe climbing procedure in all weathers.

The Climbing Protection Panel can also be efficiently moved with mobile, weight-optimized climbing hydraulics. The cylinders and hydraulic pump are conveniently transported on the floor slab.



Assembly versions

With 4 different assembly versions, the RCS P Climbing Protection Panel can be optimally adapted to suit the respective requirements.

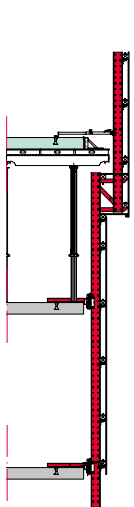

Version 1
Standard assembly with narrow working platform.

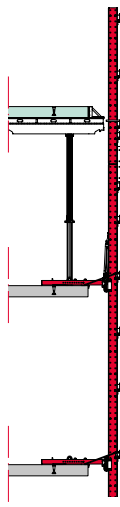

Version 2
The simplest version with a continuous climbing rail in case no working platform is required.

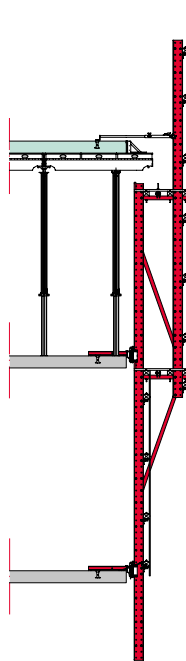

Version 3
This version with 2 wide working platforms provides surrounding access and space for pre-tensioning the floor slab.

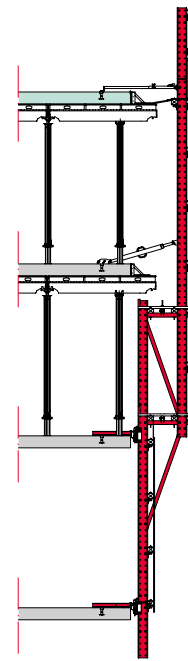

Version 4
The version with 2 wide working platforms for enclosing the 2 topmost floors under construction accommodating double on-site formwork material quantities.

The completely shielded working area provides protection against the wind and weather. In addition, the enclosure creates a sense of safety that significantly increases the working productivity.



For special solutions with hydraulic folding units of the Climbing Protection Panel, large-sized slab tables can easily be moved.

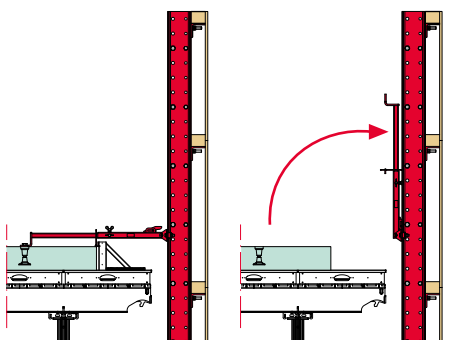

Slab Anchor Template

The Leading Anchor can be quickly and easily positioned with the foldable Slab Anchor Template. This saves time-consuming measuring procedures. After concreting, the template is simply folded up whereby it automatically locks in a vertical position.

Complete all-round safety

Flaps with overlying rubber mats ensure that the gaps between the enclosure and slab are completely covered. During the climbing process, the flaps can be fixed to the Climbing Protection Panel.

Adapter VT 20/RCS P

With the Adapter, VT 20 Formwork Girders can be used as a supporting Climbing Protection Panel. These are available from the rental parks which in turn increases the cost-effectiveness of the climbing solution.

RCS P Climbing Protection Panel

Enclosure variants for all requirements



PERI offers a number of enclosure versions. This facilitates optimal protection for all construction site requirements and for any climate.

The enclosure is selected according to the project and region. In cold weather conditions, for example, enclosed storeys with wooden multilayer panels or corrugated steel sheets can be heated. Permeable structures such as perforated steel sheets or LPS Mesh Panels, however, have the advantage that they prevent heat accumulation inside buildings in warmer climate zones. In addition, they provide sufficient light inside in the building.

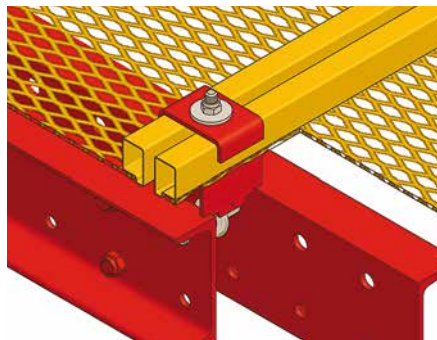

The lightweight LPS Mesh panels are easily and quickly mounted to the climbing rail by means of clamp connectors.



Here, the Climbing Protection Panel not only serves as all-round anti-fall protection for the top 3 floors under construction but also as highly visible advertising space.

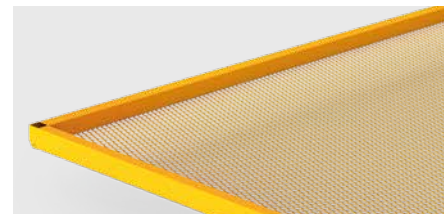

LPS Mesh Panel

Working safety is guaranteed thanks to the close-meshed expanded metal grating in spite of the strongly reduced wind exposure area.



Closed corrugated steel sheets

An alternative to the wooden multilayer panels for colder and moderate climate zones, in particular for multiple usage.

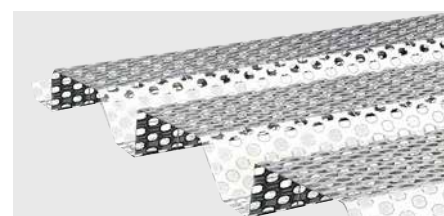

Perforated corrugated steel sheets

In warmer regions, the perforation prevents heat accumulation in the building whereby working safety is unaffected.

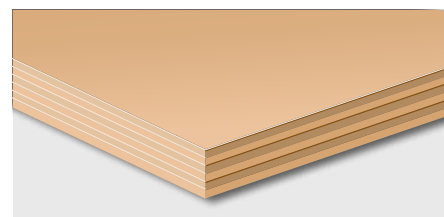

Wooden multilayer panels

The inexpensive version for colder regions if the floor is to be heated. In addition, the outer surface is ideally used for advertising purposes.

RCS P Climbing Protection Panel

Reference projects



In Australia, mesh enclosures are frequently used due to the high temperatures. This allows not only air but also light to enter the building.



The repeatedly recessed facade construction characterizes the DC Tower in Vienna. The Climbing Protection Panel could be continually adjusted to match the variable floor areas.



This gap-free mesh enclosure in Japan ensured a high level of safety while simultaneously providing light and air permeability.



The RCS Climbing Protection Panel in use for the construction of the Asia Square Tower in Singapore. The integrated landing platforms ensure easy transport of materials from floor to floor.

The RCS Climbing Protection Panel secures the leading edges of the subsequently realized floor slabs in the Vodafone Office Tower in Düsseldorf. The core of the elliptically-shaped structure rose steadily increased in height with the help of RCS and ACS Self-Climbing Technology.



RCS MP Landing Platform

The flexible solution for moving loads by crane

The RCS MP Landing Platform serves to move formwork and materials on high-rise buildings. The platform can either be anchored in the slab or clamped between two floor slabs by means of MULTIPROP props.

The RCS MP Steel solution includes anti-slip checkered steel sheeting and all-round side protection on the platform using LPS Mesh Panels. This guarantees a very high level of working safety. The additional scaffold tubes positioned above also provide safe working conditions when attaching formwork tables.

As standard, the RCS MP Steel Landing Platform is available as a preassembled unit with lengths of 3.75 m and 5.50 m, with a minimum clear width of 2.52 m. Integrated attachment points simplify the moving procedure.

The high load-bearing capacity and flexible mounting options make the RCS MP an ideal piece of work equipment on any construction site – for moving building materials from one floor to any other floor in the building.

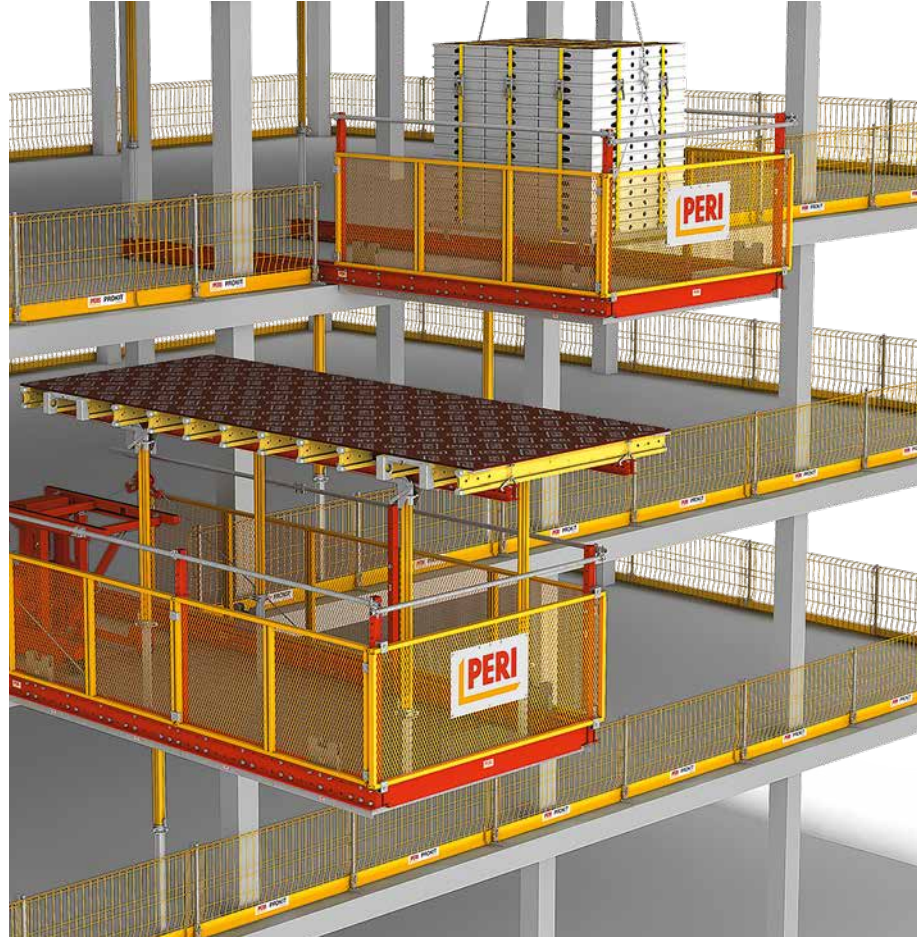

The RCS MP Steel Landing Platform is the flexible solution for moving loads by crane.



The platforms are 3.00 m wide. They can be stacked pre-assembled and space-savingsly transported. The guardrails are simply inserted on the construction site and secured by means of bolts.



Special platforms with GT 24 Formwork Girders

Alternatively, platforms for the Landing Platform can be realized with GT 24 Formwork Girders and RCS Climbing Rails. Such special platforms are planned and mounted according to site-specific requirements.

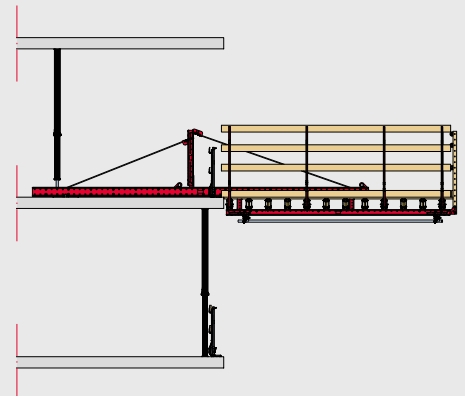

With additional loads, RCS Climbing Rails serve as load-bearing profiles of the RCS Landing Platform depending on the cantilever and load.

Variable positioning

The platform can be freely positioned at any place on the building whereby different mounting options are available:

1. Anchoring of the RCS carrier profiles in the slab with climbing anchors or tied through the concrete by means of DW 15 Tie Rods.
2. Clamping of the carrier profiles between the floor slabs with MULTIPROP Slab Props – without any mounting parts or drilling into the slabs.

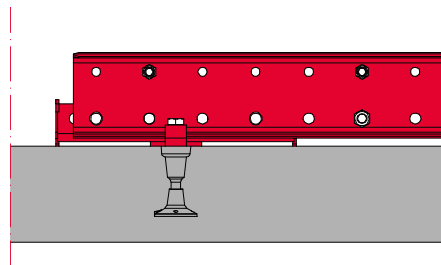

Anchoring in the slab

Through the use of the RCS M24 Slab Support Anchor Shoe and the certified M24 Climbing Anchor, the platform can be anchored in the slabs of the building.

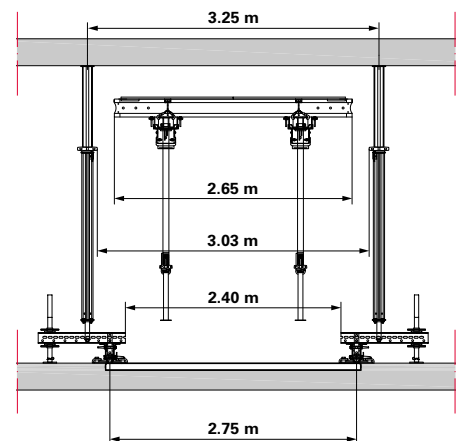

Clamping between the slabs

If MULTIPROP props are positioned on additional SRU Walers, the passage opening is over 3.00 m wide and therefore also suitable for large-sized tables.

RCS ML Material Lifter

The complete solution for moving slab tables without a crane

The two-piece material lifter consists of a self-climbing landing platform and a lifting bracket with integrated Hoisting Trolley. As a result, slab tables can be moved up to 3 storeys (max. 20 m) without any crane assistance.

The rail-guided climbing of 2 transportable units is carried out with the help of RCS Self-Climbing Devices. As the Landing Platform and Lifting Unit are separated from each other, the weight to be moved during assembly and when climbing is only 3.5 t. For the transportation of slab tables or pallets with panel slab formwork, a Hoisting Trolley is used with a 1.6 t lifting capacity.

An additional safety feature: the Hoisting Trolley raises the load over the assembled guardrails on the top floor slab; time-consuming opening and closing of loading gates is not required.

Climbing procedure

When using the RCS Climbing Hydraulics, the Lifting Bracket is climbed to the next storey first; materials can now be lifted through a height of 2 floors up to the topmost floor slab. Following this, the Landing Platform is also climbed one floor.



Lifting Bracket and Landing Platform

The topmost set of guardrails remains in position – the load is simply lifted over them.

Lifting procedure

Simple moving procedure with the PERI RCS ML Material Lifter in only 4 steps over 2 storeys:

1. Move the table form onto the landing platform using the Table Trolley and attach with slings
2. Hoist the table form by means of the chain hoist
3. Move the table form over the mounted guardrails into the building by means of the Hoisting Trolley
4. Lower the table form onto the top Table Trolley

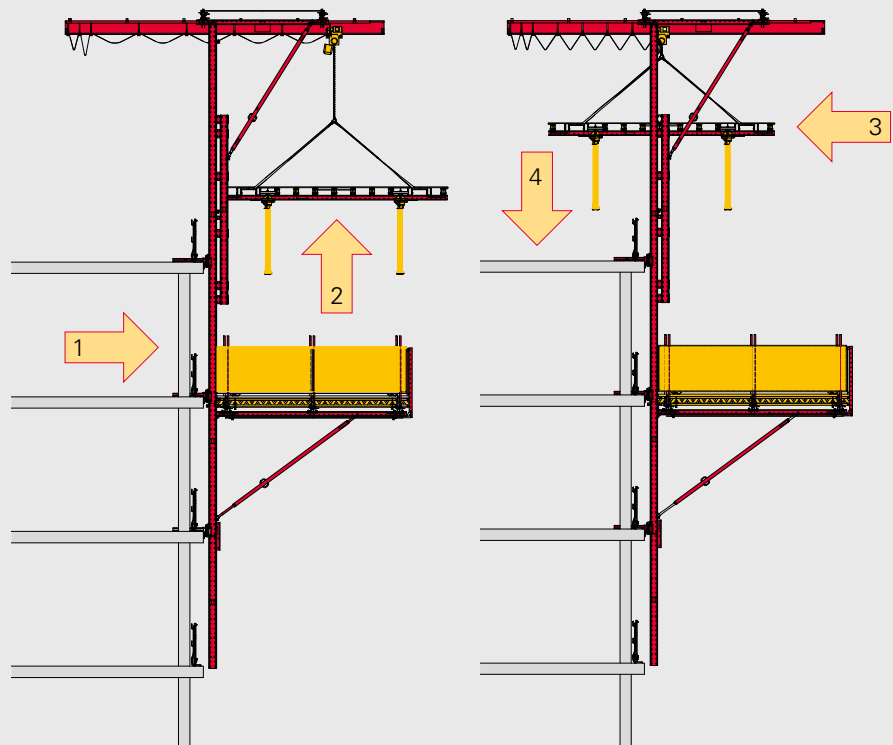

The self-climbing Landing Platform can also be used without Lifting Brackets. It is rail-climbed using RCS Self-Climbing Technology – no crane is required thereby saving a significant amount of time.

As standard, Slab Shoes and RCS Climbing Shoes are used for mounting to the slab while anchoring is carried out with the M24 Anchoring System. One big advantage: the platform along with the supporting structure is mounted on the outermost edge of the slab. As a result, there are no load-bearing profiles or slab props causing obstructions inside the building. Working areas are therefore free of any restrictions. With the RCS Wall Shoe, anchoring is also possible in perforated facades or columns.

The Landing Platform is delivered already pre-assembled, and it can be transported as a foldable unit on a truck. The dimensions can be easily adapted to suit the respective jobsite requirements.



This self-climbing RCS Bracket Platform with 2 finishing platforms on a high-rise building is anchored in the facade columns by means of the RCS Wall Shoe.

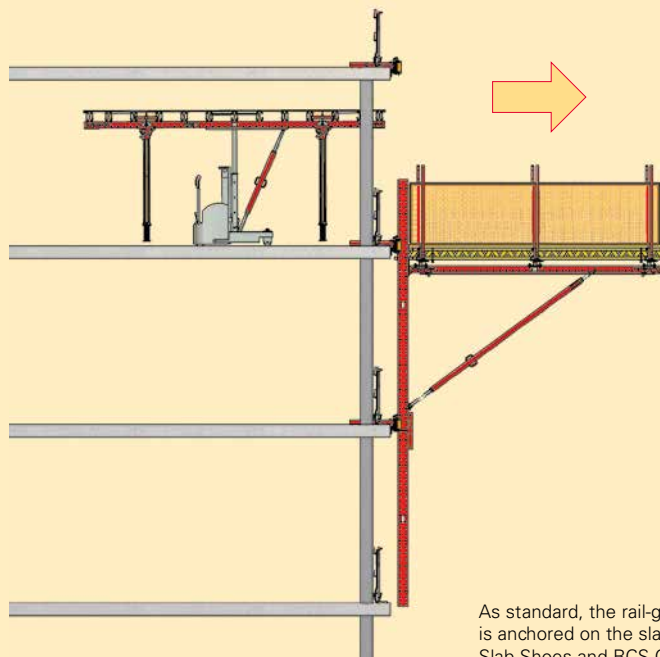

As standard, the rail-guided Landing Platform is anchored on the slab edge. For this, RCS Slab Shoes and RCS Climbing Shoes are used.

Special solutions with the RCS Rail Climbing System

Wide range of possibilities thanks to the construction kit logic

The system components of the RCS Construction Kit can be used extremely flexibly for special applications – especially in combination with components taken from the ACS Self-Climbing System and the VARIOKIT Engineering Construction Kit.

RCS Climbing Rails with the regular 125 mm hole pattern offer a high level of flexibility and numerous combination possibilities with components of other PERI systems. This results in a wide range of constructions for project-specific requirements with a very small number of special components.

As PERI stores all system components in its rental parks such special applications can be implemented extremely cost-effectively and without high investment costs. In addition, the high proportion of rentable system components guarantees fast material availability.

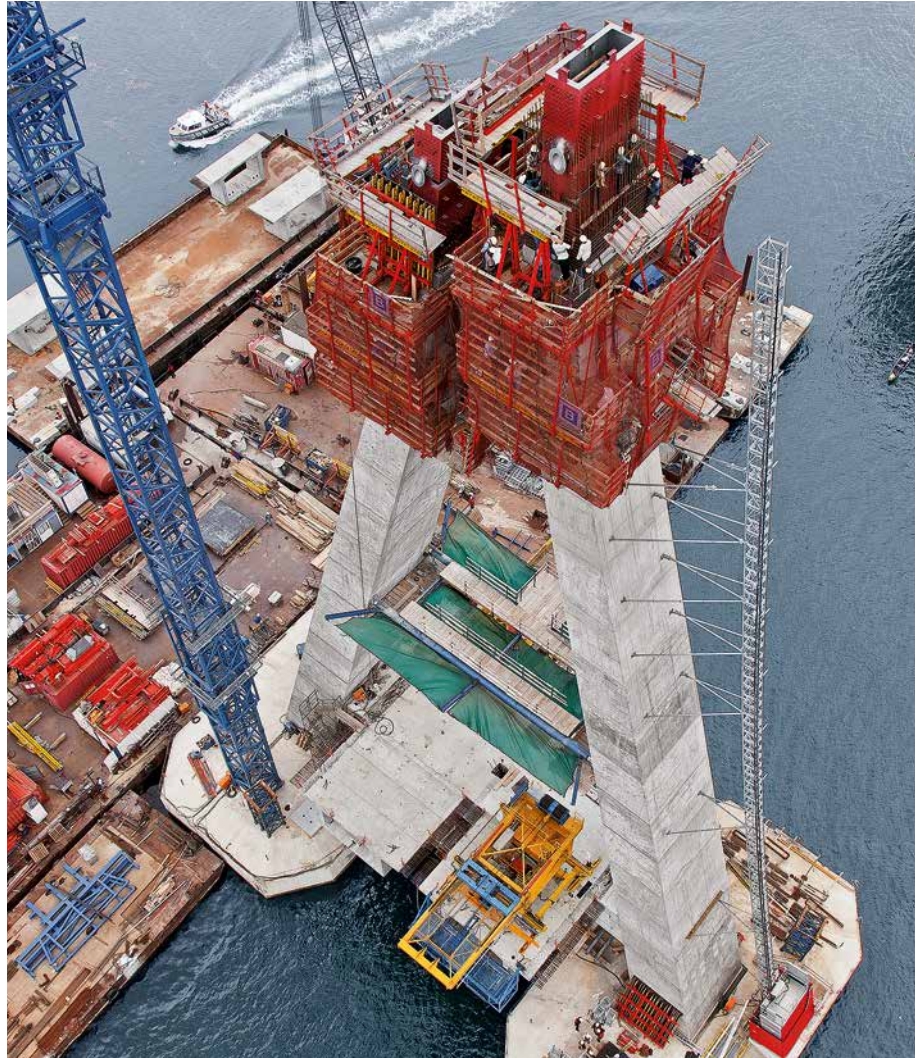

For the pylon of a bridge in Nigeria, PERI combined the ACS and RCS systems. Crane-independent working ensures rapid construction progress in spite of the continuously changing pylon inclinations.

Integrated access solutions with PERI UP: a climbing stair tower provides safe access to the finishing platform of the self-climbing system or to the topmost storey slabs under construction; it is positioned on a cantilevered platform.





With a 150° rotation, the Evolution Tower twists its way upwards into the Moscow sky reaching a height of almost 250 m. Inclined and crane-independent climbing RCS Protection Panel Units provide a very high level of safety.



Landing Platforms can also be rail-climbed by means of the mobile RCS Climbing Hydraulics – this additionally minimizes crane usage.



Here, the climbing rails of RCS Protection Panel follow the inclined form of the structure. Special slab shoes guarantee secure connection of the rails to the structure.



Trusses comprised of rentable RCS and VARIOKIT System Components not only carry the fresh concrete loads of the balconies but also the protection panel construction for the upper floors.

RCS Anchoring

Flexible mounting solutions for the RCS Rail Climbing System

Flexibly usable anchors ensure that the climbing rails are securely mounted on the structure – suitable for any building geometry.

The climbing shoe guides as well as provides support for the RCS Climbing Rail. It securely connects the Climbing Formwork Unit or Climbing Protection Panel to the building during the entire climbing procedure. As a result, it is not possible for the RCS Climbing Unit to “drift” during strong winds thus making the climbing procedure extremely safe. The integrated climbing pawl automatically engages the bolts of the climbing rail and secures the unit at 50 cm spacings.

For anchoring the climbing shoe to the wall or slab, the PERI product portfolio features a wide range of wall and slab shoes. With alternating projecting and recessed slab edges, cantilevered RCS Rails with corresponding Adapter provide the most suitable solution.

Anchoring in the wall

Standard anchoring of the RCS Climbing Formwork is carried out with the RCS Wall Shoe and RCS Climbing Shoe. The Climbing Shoe provides the necessary flexibility in order to attach the Climbing Rail with up to $\pm 4^\circ$ inclinations. Thus, the formwork can also climb over wall offsets. Due to the foldable skids, the climbing unit can be easily mounted; a complicated threading procedure is not necessary.

For anchoring on circular walls, a rotatable Wall Shoe is available with a pivoting range of $\pm 15^\circ$.

The M30 Anchor System is used for both wall shoes.

Top view:

RCS Wall Shoe and RCS Climbing Shoe

Due to the foldable skids, the climbing shoe can be laterally dismantled. In addition, this simplifies the initial assembly.

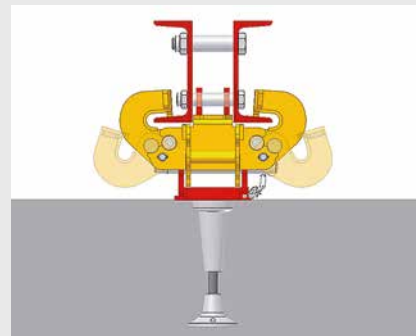

Section:

RCS Wall Shoe and RCS Climbing Shoe

The articulated connection allows vertical inclinations of the climbing rail of up to 4° . For 3.00 m floor heights, wall offsets of up to 20 cm, for example, can be climbed over.

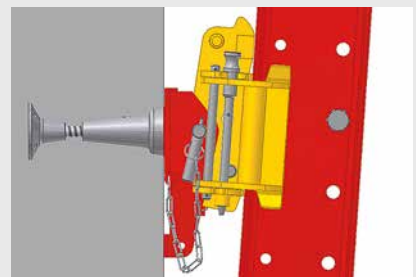
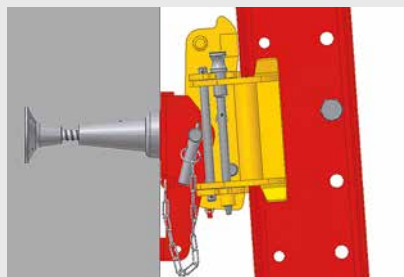

Top view:

RCS Wall Shoe, pivoted and RCS Climbing Shoe

The right solution for circular structures which feature a pivoting range of $\pm 15^\circ$. This ensures that the brackets are arranged parallel to each other, and the carriage together with the formwork can be retracted.



Anchoring in the slab

The RCS P Climbing Protection Panel is normally anchored with the RCS Slab Shoe and RCS Climbing Shoe on the floor slab. The Climbing Rail is thereby arranged with a 15 cm clearance to the slab edge. The RCS Slab Shoe Adjustable 30 allows cantilevers from 15 cm to 45 cm. Both slab shoes are anchored with M24 Climbing Anchors.

The Stopend Slab Shoe is used on the corners of a building or in the area of offset columns. A Stopend Slab Anchor serves as anchorage which is fixed in advance to the Stopend Formwork.

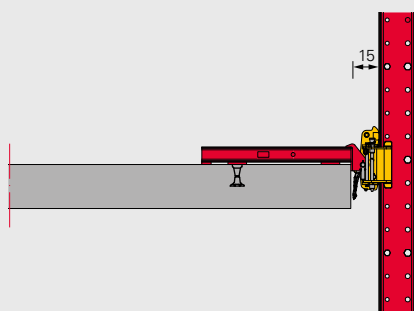

RCS Slab Shoe

Standard anchoring of the Climbing Protection Panel: the Climbing Shoe is mounted on the slab edge with the RCS Slab Shoe. On building corners, an RCS Slab Shoe Corner is used transversely.

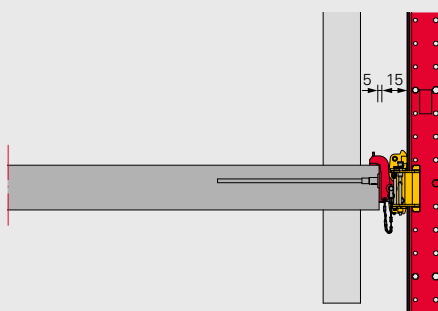

RCS Stopend Slab Shoe

The Stopend Slab Shoe is used for mounting the Climbing Shoe on the front end of a slab while the anchoring is carried out by means of a Stopend Slab Anchor.

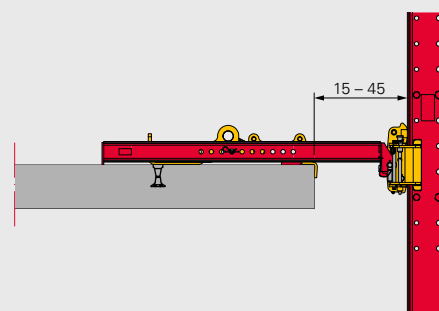

RCS Slab Shoe Adjustable 30

The RCS Slab Shoe Adjustable 30 provides a 30 cm adjustment range. It can be used for projections of up to approx. 45 cm.

RCS Slab Support

For very large cantilevers, in the order of 2.0 m, the slab support components (Anchor Shoe, Adjusting Shoe, Adapter) are connected with a horizontal RCS Climbing Rail. Thus, for buildings with alternating projecting or recessed slab edges, the RCS Climbing Protection Panel can also be guided up the structure in a line.

- 1 Slab Support Adapter RCS
- 2 Climbing Rail RCS
- 3 Climbing Shoe RCS
- 4 Slab Support Anchor Shoe RCS M24
- 5 Slab Support Alignment RCS

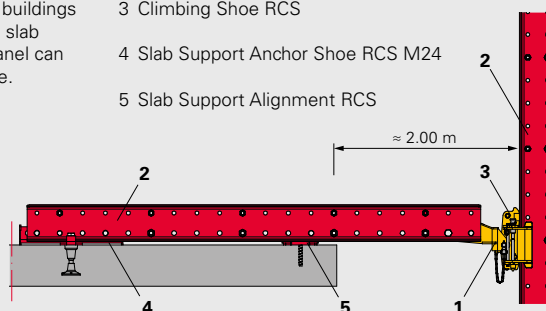

RCS Self-Climbing Hydraulics

Cost-effective climbing without use of a crane with mobile RCS Climbing Devices

The weight-optimized components of the mobile climbing hydraulics are easy to transport and extremely simple to handle.

The RCS C and RCS CL Rail Climbing Formwork along with the RCS P Climbing Protection Panel and the RCS ML Material Lifter can also be hydraulically climbed without a crane.

The use of mobile self-climbing devices and hydraulic pumps is also cost-effective for structures with lower heights as only one hydraulic kit is required for climbing all the units. As an option, the mobile self-climbing equipment can also be retrofitted at any time.

Flexible climbing with RCS

With the RCS Rail Climbing System, the Climbing Rail is not climbed in advance but is an integral part of the system. The RCS 50 Climbing Device raises the climbing unit in 50 cm increments. Two climbing units are climbed the height of one storey with one hydraulic kit in each case. In the process, the Climbing Device is positioned on the Climbing Shoe and is moved to the next climbing units after the climbing procedure is completed.

Functionality details

The Climbing Device works together with the self-operating bearing pawl in the Climbing Shoe. The claw on the upper end of the piston of the hydraulic cylinder engages the climbing bolts of the Climbing Rail and pushes this with the formwork scaffolding or protection panel 50 cm upwards. At the end of the stroke, the bearing pawl of the Climbing Shoe engages the climbing bolts which are arranged below. It accepts the load while the cylinder retracts thereby avoiding the next climbing bolts, and then engages this.



The hydraulic cylinder with its 5 t lifting capacity is positioned on the climbing shoe.



The climbing units are raised with a lifting speed of 1 m/min.

Anchoring

Independent of the type of anchoring, the RCS Climbing Device reliably operates in connection with the pawl in the climbing shoe.

RCS C Climbing Formwork

Anchoring in the wall

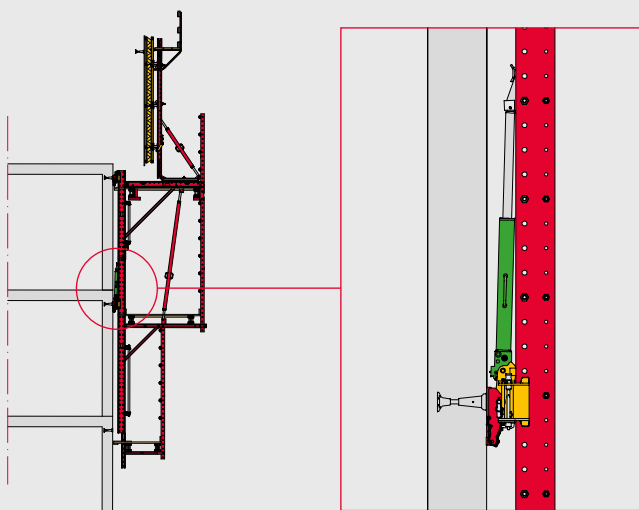

RCS P Climbing Protection Panel

Anchoring in the slab

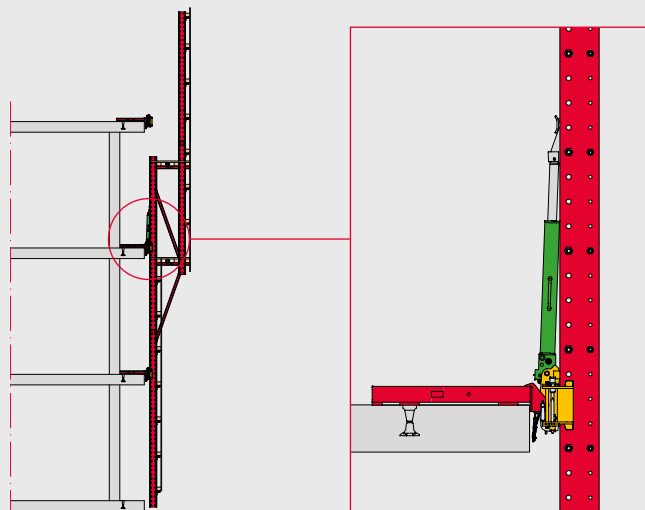

On the RCS Hydraulic Pump, up to four RCS 50 Climbing Devices with hydraulic double hoses can be connected. The integrated flow divider ensures synchronous climbing thus preventing a collision of the climbing units.

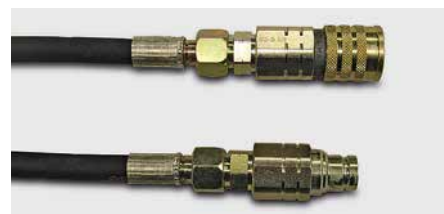

The quick couplings of the double hoses are connected within seconds to the hydraulic cylinder and pump. The clearly arranged socket and nipple avoids any incorrect connections as well as allowing easy installation.

**The optimal System
for every Project and
every Requirement**



Wall Formwork



Column Formwork



Slab Formwork



Climbing Systems



Bridge Formwork



Tunnel Formwork



Shoring Systems



Construction Scaffold



Facade Scaffold



Industrial Scaffold



Access



Protection Scaffold



Safety Systems



**System-Independent
Accessories**



Services



PERI AG
Formwork Scaffolding Engineering
 Rudolf-Diesel-Strasse 19
 89264 Weissenhorn
 Germany
 Tel. +49 (0)7309.950-0
 Fax +49 (0)7309.951-0
 info@peri.com
 www.peri.com

